

# MCG SURGE PROTECTION

## The Truth of the Matter

### A Surge Protection Tutorial

It has become very difficult for those selecting surge protection to choose the most reliable, yet cost-effective protection devices in the marketplace.

Making the right selection should be painless, and with sufficient knowledge and some common sense, it can be.

The following is a collection of topics relating to transient voltage suppression presented in a format that is concise and accurate.

## Contents

## Page

---

### FAQ on Surge Protection

3

---

### Lightning and Transients Considerations

Anatomy of a Lightning Strike

5

Economic Justification for Surge Protection

6

---

### Surge Protection Overview

System Protection Recommendations

7

Suggested "Product Comparison Sheet"

8

---

### Major Issues That You Need To Consider

Peak Current Capability

9

Protection Guidelines

10

"Let Through" Voltage - Can It Be Reduced?

11

"Let Through" Voltage - Wire Size Considerations

12

Micro-Z Concept - For Better Performance

13

Voltage Drops Along Power Cabling

14

High AC Line Voltage - Requires Several Strategies

15

---

### Other Important Issues

Fuse and Thermal Disconnect Strategies

16

Redundancy - True vs. False Redundancy

17

Modular Design Considerations and Problems

18

Monitoring and Diagnostics

19

Life Expectancy

20

Environmental Factors

20

Enclosures - NEMA

20

---

### Installation Notes

Installation Q & A

21

Wiring Diagrams/Phase Connections

22

Safety Disconnect Switch Considerations

23

Ground - The Single Point Concept

23

---

### Promoted Ideas of Questionable Merit

Sine Wave Tracking and EMI/RFI Filtering

24

Hybrid Protection Circuitry

25

UL Listed Versus UL Compliant: What's the Difference?

26

---

### Observing the Passing Scene

Open Technology - Why the Secrecy?

27

Advertising - Exotic Uses of the English Language

28

---

### Standards

Standards - Industry and Safety

29

ANSI C62.41-2002 Waveforms

30

---

### Glossary of Technical Terms

31

### Warranty

31

### Index

32

---

Copyright 2008. ALL Rights Reserved.

MCG Surge Protection • 12 Burt Drive • Deer Park, NY 11729 • WWW.MCGSURGE.COM • Phone (631) 586-5125 • 1-800-851-1508

# FAQ: Surge Protection

## Why Surge Protection?

The tremendous proliferation of the use of sensitive electronic equipment, sensitive by virtue of the circuit having literally millions of transistors on a single chip, predisposes any discussion on the need for surge protection.

The increasingly vulnerable circuitry exists in an extremely hostile environment. It is subjected daily to potentially disruptive and destructive surges from industrial accidents, utility network switching, and, of course, lightning strikes. The most logical and cost-effective defense is surge protection. To best serve your needs, define what you want to accomplish:

- For blackouts, brownouts and dips, choose a UPS.
- To protect a UPS, choose a surge protector.
- For upset or damage by surges, choose a surge protector.
- For I/O port damage, choose a data line protector.

## What is the proper protector size?

A surge entering a facility will dissipate by subdividing throughout the building's power distribution system.

The capability of a surge protector is determined by its intended location. At the point of entry the energy contained in the surge is at a maximum. Fanning out on its journey through the system, it will offer less magnitude to each branch panel encountered. Finally, the least amount of damaging surge current will be experienced by outlets deep in the system.

## Why Surge Protection by MCG?

MCG Surge Protection has specialized in the design, development and manufacture of high quality lightning, surge and transient overvoltage protection devices since 1967. MCG pioneered many of the innovations that are commonplace today such as modularity, redundancy, very low impedance, "Micro-Z" wiring, extensive local diagnostics for ease of servicing, event monitoring, audible alarm, etc.

## How do I choose a surge protector?

The specifier and user of an SPD has the unenviable task of sifting through the many and widely varied performance data from surge suppression manufacturers. One would be prudent to question unrealistic or non "real world" claims. Specification data should be documented and further substantiated with evidence such as scope traces verifying testing against defined waveforms. Disclosure of technology should be insisted upon and bashful manufacturers considered suspect.

## How does an SPD work?

Suppression of transient surges and overvoltages is achieved by the use of metal oxide varistors (MOV), installed in shunt with the AC power lines. The MOV, under normal conditions, is a high resistance element rendering it virtually invisible on the line. Any transient exceeding the threshold (typically 125% of nominal) will cause the MOV's resistance to drop rapidly (in nanoseconds) to provide a very desirable path for the excess surge current. An effective SPD will divert damaging transients harmlessly away from the sensitive load with nanosecond speed.

## What exactly is meant by "Micro-Z"?

Any impedance between the power line and ground will inhibit the diversion of transient current to ground. Two conditions are necessary for a surge diversion to be effective:

1.) Keep the surge impedance of the leads connecting the SPD to the AC power line low by making wiring short and direct. Dress all leads tightly together and tape the wire over the full length of the wire run. MCG's proprietary Micro-Z cabling has 50% less drop than well-constructed conventional cabling.

2.) The internal surge impedance of the SPD must be reduced by careful attention to design. Patented MCG Micro-Z circuitry has been designed to create a low impedance surge path through the protection device which significantly reduces the voltage drop across internal SPD wiring.

Combining the benefits of a low internal SPD impedance with a low impedance connection to the AC power permits MCG to use higher voltage MOVs without a sacrifice in the surge suppression performance. The additional headroom above the nominal +/- 10% power line voltage translates into longer SPD life.

## Response Time - How fast should it be?

Claims are made of less than one nanosecond response (and occasionally) less than one picosecond to clamp a transient. This should prompt some thought. A nanosecond is one billionth (with a 'b') of a second. WOW! How does one physically measure this speed to verify the claim? A glance at published literature released by MOV manufacturers shows these numbers, but further reading will disclose they are based on the MOV element operating in lead-less, coaxial environment. NOT REAL WORLD. It is only common sense that the MOV placed in an SPD must have leads to the power line and the resultant inductance makes the response times claims unrealistic. Organizations such as NEMA and Underwriters Laboratories have chosen to ignore this specification

*(con't on p.4)*

completely since MOVs have response times 100 to 1000 times faster than any transient they are likely to encounter.

### **What is the difference between Threshold Voltage and Clamp Voltage?**

Threshold Voltage is the point at which an SPD conducts when 1mA of current is being delivered to the input. By itself, this is an incomplete as a performance criterion. Clamp is the voltage measured, with an oscilloscope, at the SPD terminals when standard test waveforms, such as defined by ANSI/IEEE C62.41-2002, are applied.

Underwriters Laboratories Standard UL 1449 3rd Edition establishes suppression ranges for comparing SPD (surge protecting device(s)). Hardwired units are tested at 6,000V (1.2 x 50µs), 3,000A (8 x 20µs) and the VPR (Voltage Protection Rating) is determined for each protection mode. As an example, an established UL VPR is 600V. If actual measured test results for three samples tested in the Line to Neutral mode were 550V, 590V, 495V, the VPR assigned to that protection mode would be 600V. This lets the reader know what the protector will let through when exposed to this industry standard waveform. Keep in mind that actual field performance may be better or worse depending on installation.

### **What is Nominal Discharge Current ( $I_n$ )?**

Nominal discharge current is a multiple pulse surge test featured in UL1449 3<sup>rd</sup> Ed. Manufacturers choose one of several peak current levels listed in the standard that the protector is tested to. The protector must be able to not only survive the multiple surge tests on a per mode basis, but also the let-through voltage established before and after the multiple pulse sequence must remain within close tolerance (+/-10%) of each other.

For most service entrance applications, an  $I_n$  rating of 10kA is more than adequate for most sites. And 10kA or less is sufficient for mid-building applications. For small panels deep within a facility, a SPD with a rating of 3kA is sufficient. However, there are some cases where a more robust protector is required in the service entrance and this is where SPD with  $I_n$  equal to 20kA are employed. Be sure to question a surge protection specification that arbitrarily, without any technical basis, requires an SPD with a  $I_n$  of 20kA, especially if it is a mid-building location or small panel deep within a facility.

### **What should I know about Energy Absorption?**

A metal oxide varistor will divert, absorb and dissipate the energy of a transient. It follows that this activity should be

measured in units of energy (joules). More joules generally translates to longer design life. However, a manufacturer should substantiate the published data.

If a surge protector has a rating of 4000 joules, (8x20µs) and another has a rating of 2000 joules (8x20µs), then the 4000 joule protector has a life expectancy 10 times greater than that of the second protector. Joules matter!

### **What does “Surge Current” (8x20µs) really mean on an MCG data sheet?**

These are life ratings. To illustrate, an SPD has a 10,000 event rating at a 5,000A (8 x 20 µs) level. This indicates that the SPD can divert a surge with a maximum current of 5,000 Amps, ten thousand times. This translates to protecting your equipment from a 5,000A surge every single day (holidays included) for 27.4 years. Not bad! What is the likelihood of that occurring? Very unlikely. Consequently the SPD’s life will be very long.

A protector’s single shot rating or its “one-time” rating is also useful to know. This rating means the protector can divert a surge of that magnitude for one shot. After that, the protector will probably need to be serviced or replaced. So for a given surge environment, it is wise to specify a protector with a single shot rating that is many times higher (like 15 to 20) than the largest current that it is likely to see. This approach yields long protector life.

The single event rating on a data sheet is often used to compare and specify SPD. Usually this rating is expressed using the industry standard (8 x 20 µs) current waveform. The unit of current is used because an SPD’s primary function is to divert surge current and it is much less ambiguous than comparing other parameters.

### **What is meant by “Modes of Protection”?**

Modes of protection are MOV (metal oxide varistor) surge components connected from a Line to Neutral, Line to Ground, and Neutral to Ground. For a Wye system, this means 3 Line to Neutral, 3 Line to Ground, and 1 Neutral to Ground, or 7 modes of protection total.

### **Tracking the sine wave - real or myth?**

Both, actually. The purpose is to eliminate electrical “noise” and this is usually accomplished by adding capacitors to the protection circuitry. Since electrical noise generally is local in origin (copiers, fluorescent lights, vacuums, etc.) the real place to effectively solve this problem is at the equipment level. Protecting against noise at the building point of entry (before the noise) would appear to be something of a myth.

# Anatomy of a Lightning Strike

## What You Can Expect

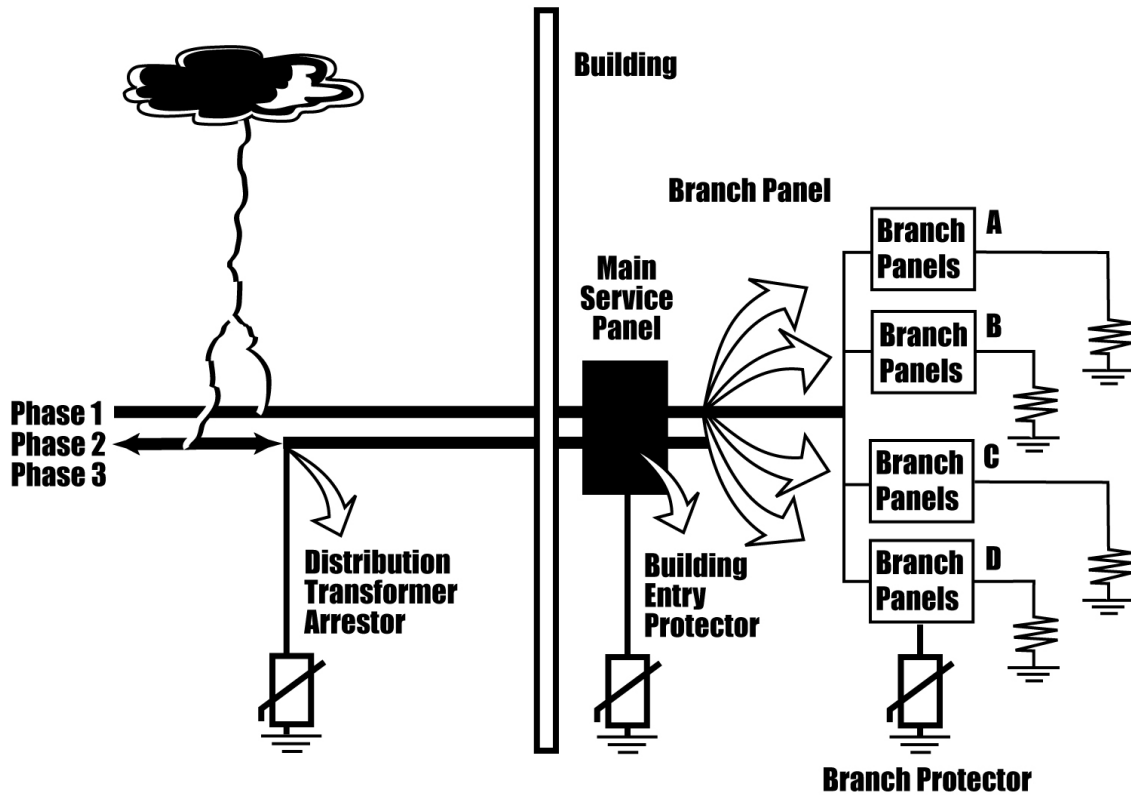

### Your First Line of Defense - Building Entry Protection

One of the largest lightning transient currents recorded was 210kA with a duration in the tens of nanoseconds. By far, the greatest threat to sensitive equipment is from lightning strikes to overhead AC power lines which then couple the transient into a facility.

### Your Second Line of Defense

Other very common sources of transient voltage spikes occur deep within a building and are caused by elevators, copiers, air conditioners, arc-welders, etc. A suitably-sized surge protector located at the branch panel will very effectively suppress locally-generated transients. Any transient voltages arriving at a protected service panel will be limited to safe voltage levels.

# **Economic Justification for Surge Protection**

## **Surge Protectors come in different sizes.**

Building entry surge protectors must provide a very substantial current diverting capability, whereas equipment deep in a building can be fitted with a much smaller protector to deal with residual lightning effects and locally-generated transients.

## **A direct lightning strike can have surge currents up to 200kA.**

These very high amplitude lightning transient current impulses are, fortunately, relatively few in number. These possible - but somewhat improbable events - should be taken seriously if a site has a history of direct strikes, nearby strikes to tall towers, strikes to industrial smoke stacks or strikes in the parking lot. These situations require a very substantial surge protection device capable of quickly and reliably diverting very large currents safely at the building entry point.

## **Fortunately, most lightning strikes are of a more moderate size**

However, they occur much more frequently, with surge currents of 5kA to 20kA and not uncommonly 100kA in amplitude. It has been estimated that lightning strikes the lower 48 states at a frequency of 9 to 20 million strikes per year.

**Another factor to consider is economic costs** associated with damaged or upset equipment and the loss of production capability and worker productivity. These unexpected costs in a critical facility, such as banks, airports, manufacturing plants, office buildings, etc., would be many times the cost of the largest surge protectors. A heavy duty surge protector, costing \$3650, using a ten year life calculation (actual life = 20+ years), will provide superb 24-hour surge protection at a cost of \$1.00 per day.

**Smaller-sized surge protectors can be employed deeper within the building at considerably lower protection cost per day.**

# System Protection Recommendations

This chart shows a typical power distribution system within a building and suggest the proper size of protectors to use throughout.

The most severe surges (lightning, utility switching, etc. ) are most likely to be encountered at the building entry or distribution panel.

A site's lightning probability, the kVA rating of the distribution transformer serving the building, and the financial risk associated with downtime will determine the proper protection recommendation (160kA+). Consult MCG for engineering evaluation.

In the mid-building area, additional transients are typically caused by cycling on and off, or start-up and shut down of large inductive loads (i.e. elevators and air conditioners) as well as fuse or circuit breaker operations. A mid-sized (100 to 150kA), plug-in, pluck out modular surge protector at the branch panel is a good choice.

At the local service panel, many of the surges result from the operation of office equipment, i.e. copy machines, fluorescent lighting and air conditioners. A smaller protector in the 80kA or 40 kA class is best suited.

For OEM applications, use an in-line AC surge protector rated at 10kA that includes filter network within.

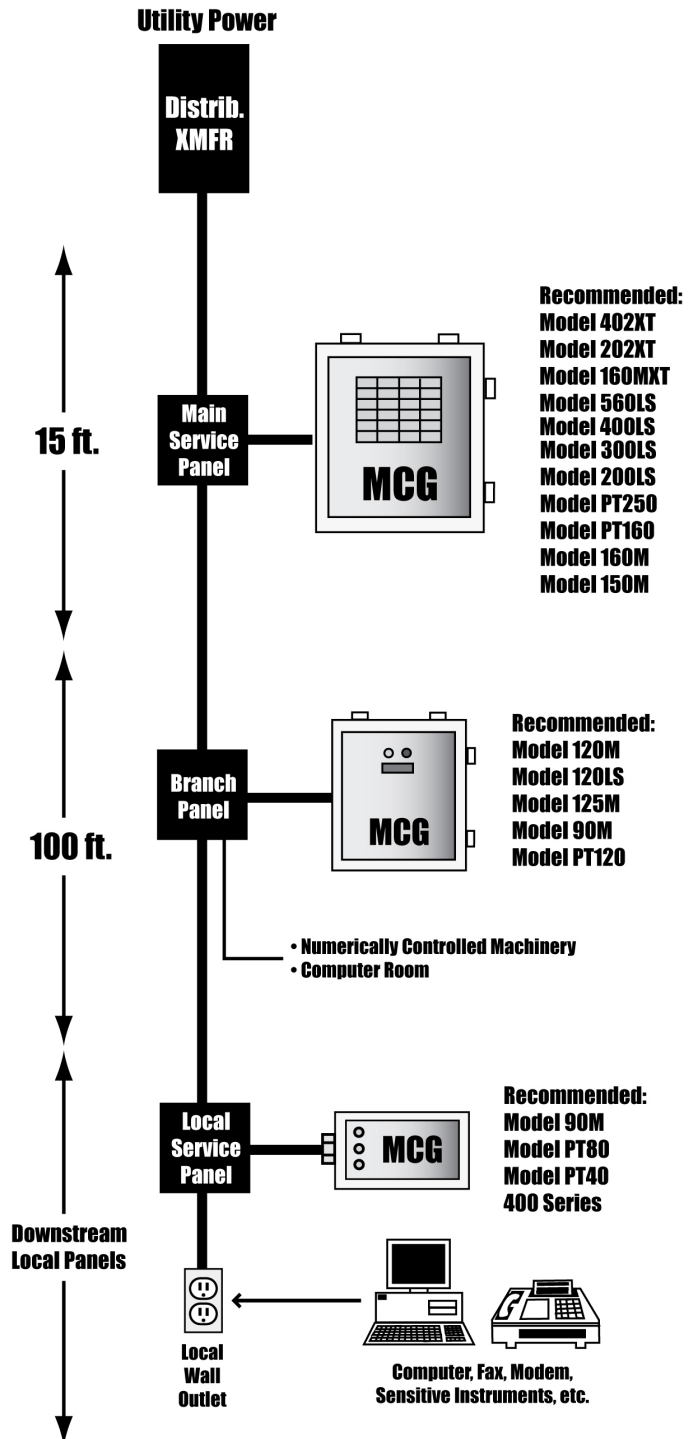

# Protection Comparison Sheet

**Location**    Bldg. Entry    Mid-Bldg.    Local Panel

**MCG**

**Competitor**

**Comments**

**Model**

**Rated Voltage** (50/60/400Hz)

**Service** (phase, wye/delta, etc.)

**MCOV**

**Performance Capability**

Suppression Voltage: 3kA (8x20us)

Suppression Voltage: 10kA (8x20us)

Response Time

Energy (Joules) 8/20us

UL 1449 3<sup>rd</sup> Edition Listed

**Surge Life (8x20) @ I Peak**

1 Event - NEMA LS-1 Rated

10,000 Events

**Diagnostics**

Transient Event Counter

Front Panel LED Indicators

Internal LED Indicators

Audible Alarm

Remote Alarm Capability

**Safety**

Fuse/MOV Coordination

Thermal Disconnect

**Maintainability**

Redundant Protection

Field Replaceable Modules and Fuses

Design Life (minimum)

**Environmental**

Operating Altitude

Operating Temperature

**Mechanical**

Enclosure Type (NEMA 4, 12)

Mounting Dimensions

Shipping Weight

**Warranty**

Unit Replacement

Replacement Modules and Fuses



## **Peak Current Capability - How Much Do You Need?**

There is no simple answer. The number of lightning strikes occurring in the lower 48 United States ranges from 9 to 20 million strikes per year. What visually appears to be a single lightning bolt may be as many as 2 to 23 separate impulses, with different peak currents and wave shapes. The peak current ( $I_{peak}$ ) is the most visible specification that a surge suppressor possesses. A surge protector size, located at the building entry, depends on geography, power line characteristics and the economic risks one is willing to accept. Smaller surge protectors can be effectively employed at branch and local service panels. A five minute conversation with an MCG engineer can save hours of design time.

### **Lightning impulse currents come in many sizes - from small to very large**

Nature, every now and then, will produce a lightning impulse current in the 200kA to 300kA range. However, the great majority of peak currents will occur from 5kA to 20kA. In the USA, telephone central offices have successfully standardized on surge protectors with 20kA, 8/20 $\mu$ s impulse ratings. Where lightning will strike is unpredictable. Targets such as open fields, golf courses, mountains, tall buildings, towers, utility smoke stacks and very frequently, overhead power lines. The greatest threat, by far, to equipment will come from lightning strikes to the power lines.

### **How is lightning defined?**

Electrical engineers and physicists in the USA, Europe and Asia have defined amplitudes and waveforms to model the parameters of the lightning stroke. Factors considered were geography, the existing power systems and the experiences of people in the field. For a building entry, the IEC Standards Group settled on a 10/350 $\mu$ s waveform, whereas the IEEE group (later ANSI C62.41) settled on the 8/20 $\mu$ s current waveform. It appears the IEC group chose a very high energy waveform to protect against every conceivable lightning strike. The ANSI C62.41 Standards Group chose the lightning current waveforms that were most likely. There is considerable disagreement within the IEC community as to the validity of the 10/350 $\mu$ s waveform. Within the ANSI C62.41 community, there is very high agreement as to the usefulness of the 8/20 $\mu$ s waveform.

The USA Approach: ANSI C62.41 - 2002

The European Approach: IEC Standard 61643

### **What Standard does MCG use and why?**

The ANSI C62.41 Standard has yielded excellent results for the sizing of surge protectors for use at the building entry and further within the building.

In addition, MCG employs the NEMA LS-1 Standard to certify its modules and building surge protectors (XT Series and LS Series) to meet 200kA 8/20 $\mu$ s impulse successfully - without damage. These devices are tested by an independent third party testing organization.

### **The Proof is in the Pudding**

The number of MOV-based surge protectors now protecting sites in the US and around the world is very high - in the millions and growing. Protector failures have been infrequent and primarily due to inadequately regulated power systems. MCG's use of high headroom varistors virtually eliminates protector failures due to common utility voltage swells.

# Protection Guidelines - CBEMA Standards

## Equipment Susceptibility to Transient Damage

Computer manufacturers do not acknowledge the sensitivity thresholds of their equipment. Their reluctance to be forthcoming is understandable since this information can and probably will be used by their competitors - to their detriment.

## FIPS Guidelines

The Federal Information Processing Standards (FIPS) publication, "Guidelines on Electrical Power for Automatic Data Processing Installations," (FIPS Pub. DU294) includes a susceptibility profile (CBEMA curve) that is a design objective for computer hardware designers. The profile shows the relationship between maximum permissible suppressed voltage levels, system voltage and surge duration.

## CBEMA Standard

The Computer and Business Equipment Manufacturers Association provided a performance profile for computer equipment known as the CBEMA curve. The curve illustrates the allowable peak transient voltage allowable when the AC line voltage and transient duration are considered.

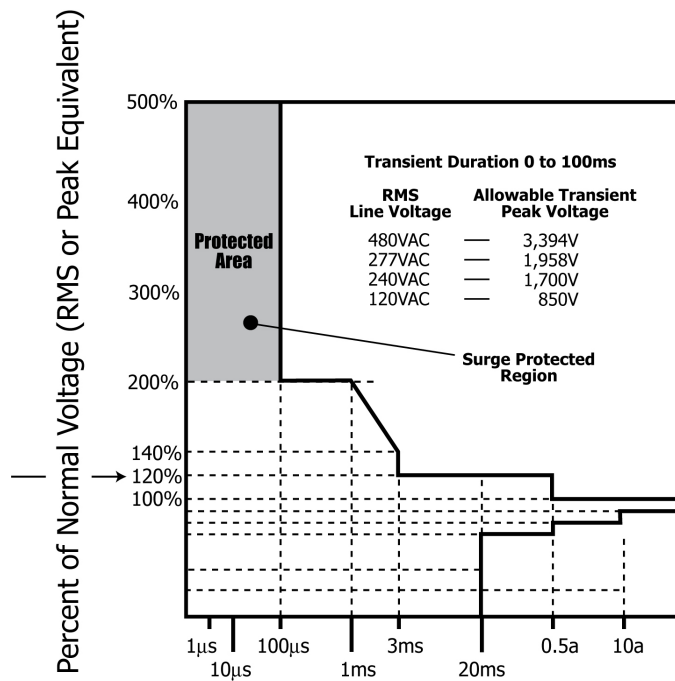

ITIC (CBEMA) Curve (2000)

Reference from <http://www.itic.org>

## Are published surge protector clamp levels realistic?

No. Surge protection manufacturers generally report only on the clamping capability of their surge protectors at the 6" (~16cm) wiring connection cable to the protector. This is a UL 1449 requirement to standardize measurement comparison between surge protector manufacturers. No concern is made of the very large voltage drops that will occur on the actual cabling between the surge protector and the service panel.

# Let-Through Voltage

## Can It Be Reduced?

Inductance of wiring presents a relatively high impedance path to ground. This can produce unwanted voltage drops which cause high “let-through” transient voltages to appear across sensitive equipment.

The diagram below illustrates the distribution of voltage drops and how the sum of the voltage drops appears across the load.

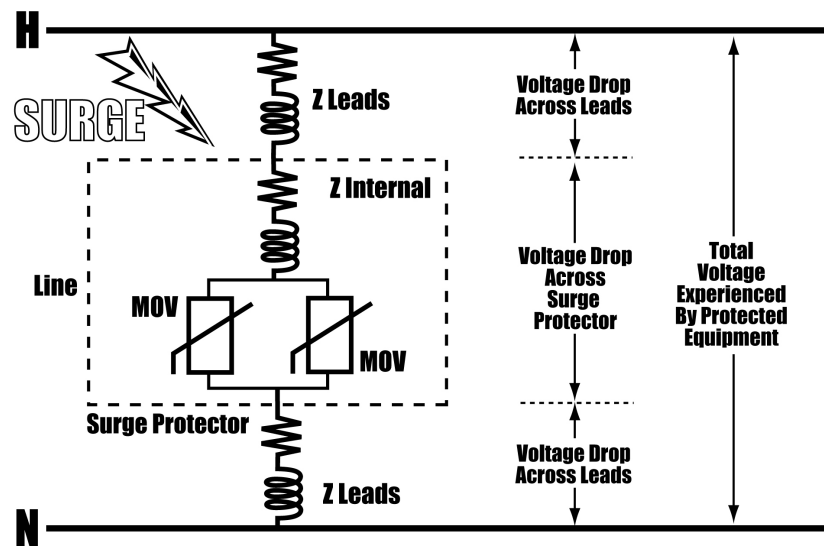

Undesirable inductance is present in the wiring from the AC power line to the protector as well as within the protector itself. Conventional protectors attempt to minimize inductive impedance by:

- 1.) Using very short wiring - minimum slack, no extra turns, no loops.
- 2.) Using very large diameter conductors for connection to the AC power line.
- 3.) Dressing all leads tightly together, taping or tie-wrapping over their full length.

While these provide some benefits, they fall short of what can be accomplished. To truly minimize inductance, the Micro-Z approach to inductive control merits your attention.

## Let-Through Voltage - Wire Size Considerations

It is desirable to limit the let-through voltage that appears across sensitive downstream equipment to as low a value as practical. Wire has two inherent characteristics that increase the let-through voltage of an installed surge protector. These parameters are its inductance in micro henries ( $\mu\text{h}$ ) and its resistance, in ohms. It is desirable to keep the wiring inductance and resistance values low to reduce the inherent voltage drop that will occur along the wire. This might imply use of large diameter wires. Large wire sizes cost considerably more in material and labor to install.

### Wire Inductance

The value of inductance increases with wire length and decreases as wire diameter increases. At a given length, the inductance of the #10 AWG wire and the 4/0 AWG cable is essentially equivalent, even though the circular mils differ by a 40/1 ratio.

A 4/0 wire inductance is **1.0  $\mu\text{h}$  for 40" length**. Area = 420,000 circular mils.

A #10 AWG wire inductance is **1.1  $\mu\text{h}$  for 40" length**. Area = 10,380 circular mils.

**Observation: The #10 AWG wire is inductively equivalent to 4/0 AWG cable.**

### Wire Resistance Considerations

The value of resistance increases with wire length and decreases as wire diameter increases, the voltage drops across the #10 AWG wire and 4/0 AWG are so low that they can be ignored.

- A 4/0 AWG wire resistance is 0.049 milliohms/ft. A 10kA pulse will have a **0.5 Volt** drop per ft.
- A #10 AWG wire resistance is 0.999 milliohms/ft. A 10kA pulse will have a **10 Volt** drop per ft.

### Conclusion

**The 4/0 AWG wire offers no significant advantage over the #10 AWG wire. For minimum let-through voltage, keep wire lengths as short as possible. Many of MCG's protectors incorporate "Micro-Z" power cabling at no extra charge.**

## Proprietary Micro-Z Concept for Better Performance

Micro-Z Concept combines the surge protector's patented internal design with an innovative external wiring configuration. The combination yields a significantly lower let-through voltage across the load. The Micro-Z approach is comprised of three parts:

### Micro-Z Cabling connected between the service panel and the surge protector

Micro-Z cabling forces a very efficient magnetic field cancellation within the cable. This results in a correspondingly low inductive voltage drop along the cable that is 50% lower than achieved with conventional wiring.

### Micro-Z Construction Approach (U.S. Patent No. 5, 303, 116)

Micro-Z construction lowers the internal impedance of the surge protector by designing the physical layout to create cancelling magnetic fields. This results in lower voltage drops across the surge protector's internal wiring.

### Micro-Z Power Buss

Micro-Z Power Buss provides massive solid copper busses for extraordinary I peak current handling capability within the surge protector.

### Conclusion

The Micro-Z concept significantly improves the surge current path to ground resulting in considerably lower transient voltage stress to sensitive downstream equipment.

### Cross Section of Cable Showing Location of Each Conductor

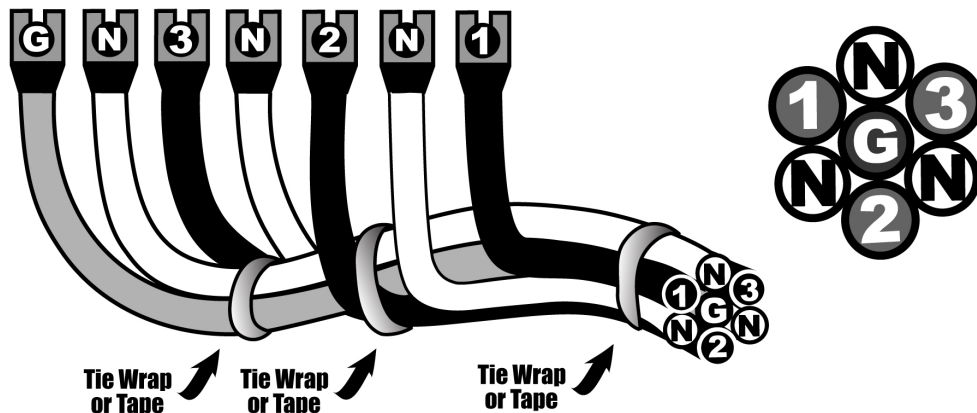

Most MCG Surge Protectors Come Equipped With Micro-Z Cable Already Installed.

# Voltage Drops Along Power Cabling

## Cable Voltage Drop - Micro-Z vs. #6 AWG

### Test Conditions:

Velonex Pulse Generator delivered a standard ANSI C62.41 waveform (6kV/3kA, 8/20 $\mu$ s) into a 12 foot cable pair, consisting of two #6 AWG power cables, tightly taped along its full length.

### Measurements:

Voltage drop measurements were made at 1 foot intervals along the cable length.

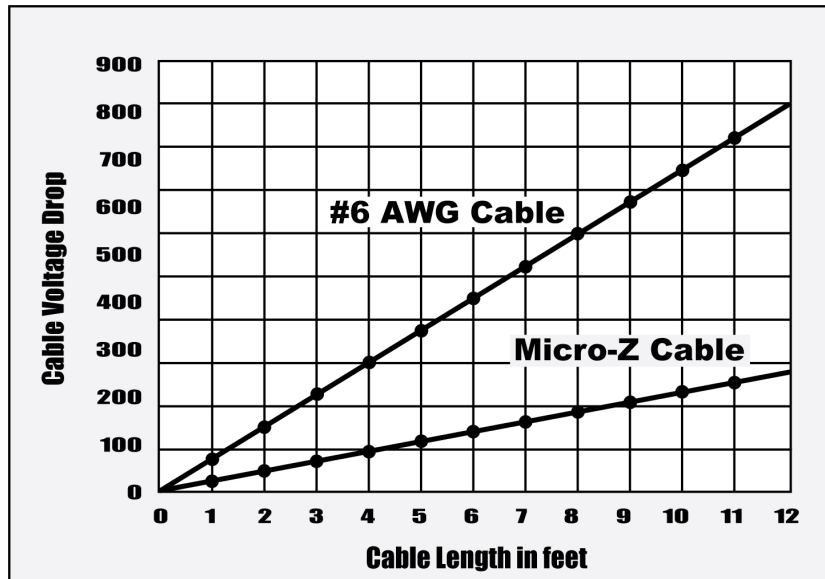

### Micro-Z Cable

Axial power cabling configuration from the protector to the service panel forces magnetic field cancellation within the cable. This results in correspondingly low “inductive” voltage drop along the cable that is up to 67% lower than conventional cabling approaches.

### Observation

Your sensitive equipment will be exposed to a peak transient voltage which is the sum of the surge protector’s “Clamp Voltage “ + the cable voltage drop, which is a function of its length.

### Example

A surge protector designed for use on a 120 VAC service will limit a 6kA/3kA (8x20) transient to a clamp voltage of 464V at its terminals,

...with 3ft. of #6AWG cable, equipment exposure totals:  $464V + 220V = 684V$

...with 3 ft. of Micro-Z cable, equipment exposure totals:  $464V + 70V =$  only 534V

Using 9 ft. of Micro-Z cable, equipment exposure totals are:  $464V + 207V = 671V$ , or about the same as 3 ft. of #6 AWG cable.

### Conclusion:

**Use of Micro-Z cable reduces the let through voltage by 150 volts.**

## **High AC Voltage: Requires Several Strategies**

A high-line condition is a long-term, abnormally high AC line voltage whose amplitude is higher than the nominal AC line voltage by 10%. MOVs are damaged when the AC line voltage exceeds the surge protector's maximum continuous voltage (MCOV), which is typically 15% above the nominal AC line voltage.

**A surge protector has competing requirements that must be met.**

*Sensitive equipment requires a low clamping voltage on the AC power line.*

The sensitive equipment must be shielded from short duration (microsecond) high voltage transients that appear on the AC power lines and cause internal damage to semiconductors, microprocessors, etc.

*The surge protector needs a higher clamping voltage if it is to survive.*

The danger to a surge protector occurs when its MOVs attempt to clamp the peak of the abnormally high AC line voltage. The MOVs will start overheating and the AC line current, producing the heating, will be well below the fuse's operating current. The heating of the MOVs will be prolonged, will produce smoke, sooty deposits and will damage itself and neighboring components. Major damage to the protector will occur.

### **The Solutions**

- Use higher voltage MOVs that are much less susceptible to AC line voltages.
- Use a Micro-Z cable connection from the surge protector to the AC power panel to keep the inherent cable voltage drop to a minimum. The lower voltage drop in the Micro-Z cable will easily compensate for the higher voltage MOVs.
- Use a protector that has internal thermal disconnects that remove any MOVs that are overheating.

### **Caution:**

**A lower clamping voltage can be achieved by using lower voltage rated MOVs. However, the small reduction in the clamping voltage is obtained at the greatly increased risk of a surge protector failure.**

# Fuse and Thermal Disconnect Considerations

## Fuse KAIC Rating

Surge protectors are connected in shunt with the AC power lines. On occasion, a severe lightning surge can cause an MOV element to fail as a short circuit, thereby compelling its series fuse to open and remove the shorted MOV from the AC power line. The fuse must be capable of interrupting the AC power line short circuit fault current. The available short circuit rms current is limited by the impedance of the distribution transformer and its connecting cables. A fuse with a 200,000 Ampere Interrupt Current rating (KAIC) has proven to be universally appropriate for almost all sizes.

KAIC ratings should not be confused with a surge protector's I peak handling capability.

- KAIC ratings apply only to a 50/60 Hertz AC power line short circuit currents.
- I peak applies to large amplitude, microsecond impulses - such as lightning.

## Fuse/MOV Coordination

It is essential that a surge protector's fuses withstand short-duration, high-amplitude transient currents without opening in the course of normal suppression activities. Proper fuse/MOV coordination further requires that a fuse open rapidly at a point just prior to the MOV failure point. For example, a 40mm MOV has an I peak rating of 40kA for an 8x20  $\mu$ s waveform. Actually it is closer to 50kA, 8x20 $\mu$ s rating. It is important that the fuse be capable of opening rapidly when the 40kA rating is exceeded. Fuse characteristics vary widely and not all fuses are suitable for coordination activities.

## Thermal Disconnect Capabilities

On AC power lines that are not well regulated, it occasionally happens that the AC power line will increase suddenly by 30 to 50%. This power line voltage will cause the surge protector's MOVs to attempt to limit the sine wave peak voltage by diverting AC line current through the MOVs to neutral. The MOVs will rapidly overheat, become a short circuit and rupture.

A thermal disconnect is a device, mounted on or near each MOV element, that responds to excessive MOV heating by mechanically disconnecting the MOV for the power line. Each MOV should be individually protected and the thermal disconnect mechanism should not be sensitive to physical orientation.

MCG currently employs thermally protected varistors in a number of protectors. These new thermally protected varistors contain an integral thermal fuse which outperforms any external thermal mechanisms, thus providing the utmost in protector safety.



# Redundancy: True vs. False Redundancy

Multiple protection paths to ground are critical. A lightning strike often consists of multiple current strokes to the power lines, or earth. As many as two to twenty strokes can occur in a single lightning event.

To provide proper system protection, the building entry surge protector needs to have at least two, and preferably several, independently-fused, parallel protection sections per phase. The failure of a single protection section in a surge protector, in a severe lighting storm for example, would then not be catastrophic. System protection would continue to be maintained.

It is recommended that this redundant concept be continued at the mid-building/branch level, while at the local service panel protectors can safely employ single protection approaches.

**Redundant “Backup” Protection Without Adequate Fusing is a Weak Link.** To achieve solid, reliable protection without nuisance fuse blowing, match a fuse’s current rating with the MOV’s peak current rating.

## False Redundancy

Multiple Current Paths: Yes  
Redundant Protection: No

If F1 fails:  
Suppression capability is completely eliminated.

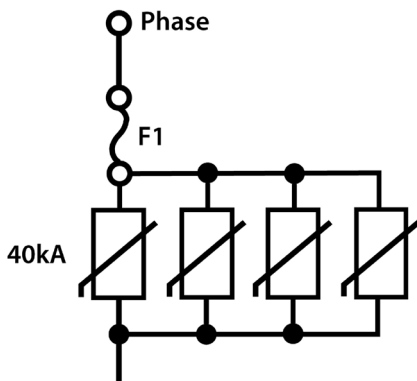

## True Redundancy

Multiple Current Paths: Yes  
Redundant: Yes - 4x

If F1 fails:  
Suppression capability is reduced to 75% of normal.

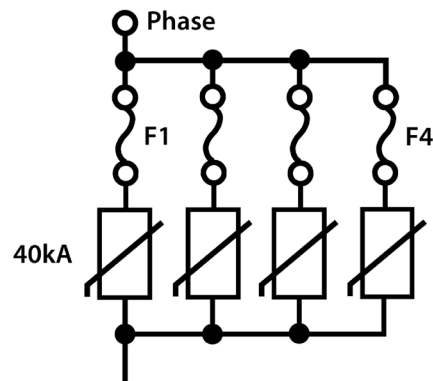

## Conclusion:

True redundancy requires multiple fuses and multiple MOVs and effective fuse/MOV coordination.

## **Modular Design Considerations and Problems**

Modular design construction is a packaging approach designed to aid repair and maintenance of a surge protector when installed at a site. Closely associated with modular design is the need to pinpoint the defective module(s) in a fault situation.

### **Locating the Defective Module**

Ordinarily, a surge protector will operate a front panel LED when an internal failure occurs. Well-designed protectors will indicate by LED (or other means) the defective module in question.

### **Protectors Employing Modular Construction are Field-Repairable**

When identified, a defective module can be quickly unplugged or unbolted. Typically, removable modules can be replaced in 10 to 15 minutes.

### **Some Non-Modular Protectors Have Several Serious Limitations**

- Should a failure be indicated, the unit or a major portion of it must be removed, replaced by a substitute, or sent to the factory for repair. These units are not field-repairable since the critical protection elements are often encased in sand/epoxy mixture.
- The use of low-cost MOVs creates a very large monitoring problem. Should each MOV/fuse combination be monitored? This greatly increases the cost of the monitoring by a factor of five times that of larger 34mm square or 40mm round MOVs. An alternate approach is to monitor groups of MOV/fuse combinations. This reduces the monitoring cost and complexity but creates another serious problem.
- When exposed to transient currents, random MOVs will fail - blowing its series fuse, but not necessarily indicating a reduced protection capability. Random failures among the various groups can lead to a greatly reduced surge protection capability, without an alarm being given.

**When protection capability is needed - it may not be there.**

# Monitoring and Diagnostics

## Why is Monitoring Needed?

Surge protectors limit transient voltages appearing on the AC power line to less than the susceptibility levels of sensitive equipment. It is important to know **immediately** whenever a surge protector's capability has diminished, either through long-term degradation in a "standby" mode or while involved in active suppression activity.

## Factors Affecting Surge Protector Capability:

### Long-Term Degradation

In spite of undocumented accounts to the contrary, extensive reliability data on MOVs indicate that there is no meaningful long-term degradation of MOVs in standby operation. See Harris "1995 Transient Voltage Suppression Devices" handbook, pages 5-10, 10-20.

### Active Service Failure

"Varistors initially fail in a short-circuit mode when subjected to surges beyond their peak current/energy ratings. They also short-circuit when operated at steady-state AC line voltages well beyond their ratings..." (Harris Handbook, page 6-6.) A surge protector correctly rated for the application will operate without interruption for 20 or more years.

### Current Monitoring Practice

Most protectors provide a fuse in series with the MOV to disconnect it from the power line should the MOV fail. By monitoring the fuse opening, the protection system signals a diminishing of protection capability. To handle very large surge currents, it is standard practice to parallel MOVs with each MOV having a series fuse. It is at this point that there is a divergence in protection philosophy.

### The Conservative Approach

Requires that all of the fuse/MOV sections be monitored and that the failure of any one section will cause an immediate, internal fault indication by LED, audible beep, etc., to occur. In addition, a front panel LED should indicate reduced protection. Some surge protectors will indicate the percentage of protection capability remaining for each phase. This approach is 100% effective. It signals a malfunction immediately with only a slight additional cost, when compared to a less comprehensive monitoring approach.

### The Minimum Approach - A Disaster Waiting To Happen

The minimum approach observes only a few, and often only one, fuse/MOV circuit combination and signals the fall off in protection capability when this solitary fuse opens. Unfortunately, some manufacturers continue to use this approach to monitor protection integrity.

**The minimum approach has a serious flaw - the unmonitored fuses may open and there will be a very substantial erosion of protection without anyone's knowledge. At some future time, a large transient surge will appear and the final fuse will open. Downstream sensitive equipment will be exposed to catastrophic damage because of an inadequate number of MOVs to handle a large surge current.**

### Conclusions

- Each fuse/MOV circuit must be monitored to avoid hidden protection erosion.
- Front panel indicators are mandatory to signal internal problems.
- Employ internal LEDs to pinpoint defective module(s) and fuse(s).
- Provide relay contact closures for remote signal capability.

# Life Expectancy

## Product Durability

It is useful to know the durability of surge protectors made by different manufacturers.

## Joule Ratings Count

The joule rating of an MOV-based protector is a direct measure of its capability to handle a large number of standardized (8x20 $\mu$ s) transient impulses. The relative life expectancy of competitive MOV-based protectors can be easily assessed by comparing their joule ratings. In any comparison, variations in joule capability by +/- 10% are not considered to be significant. Surge Protector joule rating must be compared using the same 8/20 microsecond waveform and the same MOV technology.

## The Comparison to Remember

An easy rule to remember is that if one protector has twice the joule rating of another, then it's life expectancy is ten times longer because of the nonlinear characteristics of MOVs.

## Environmental Factors

### Altitude

Operation at altitudes up to 13,000 ft. (4000m) is desirable since it covers all but the most extreme sites. High altitude surge protector designs require greater conductor spacing providing an additional margin of safety.

### Temperature

Operating temperatures of -40 degrees C to + 55 degrees C will cover most applications. It is desirable that components be rated to +85 degrees C.

### Moisture

Protector units should operate reliably in 95% humidity, non-condensing.

## NEMA Enclosures

### NEMA 4

General Purpose  
Indoor/Outdoor Locations  
Weather and Water-Resistant  
14 Gauge Steel  
Stainless Steel Hardware

### NEMA 4X

Special Duty  
Outdoor/Corrosive/Wet Locations  
Weather, Water and Corrosive-Resistant  
14 Gauge Stainless Steel  
Corrosion-Resistant, Stainless Steel Hardware

### NEMA 12

Light Duty  
Indoor Locations  
Dirt and Dust Resistant  
Drip-proof  
14 Gauge Steel  
Standard Hardware

## Installation Question and Answer

### **Should the surge protector be in the line or load side of a service disconnect?**

The surge protector, when installed on the line side of the main disconnect, will continuously protect all building loads connected to the service panel from external surges originating on the main feeders. These line side protectors are known as Type 1 SPD. However, due to their electrical distance from the connected loads on the main panel, they are ineffective at protecting these loads from surges generated from equipment within the building and from lightning surges originating on the building's grounding system during nearby strikes. Line side protectors have for many decades have been referred to as arrestors, and were typically low cost, low performance devices. Nowadays good quality and very capable Type 1 protectors exist, but the same protector located on the load side of the main overcurrent device offers benefits that a line side connected protector technically cannot, just because of where it is connected. Note: It is okay to use a Type 1 protector on the load side of the main overcurrent switch or on branch panels as well.

### **Can we install the surge protector on the load side of the main service disconnect?**

Yes, and we encourage you to do so. This is the preferred way to install a protector. A general rule of thumb is, the closer the protector is located to the loads it is protecting; the more effective it will be at protecting the loads. A service entrance protector connected after the main is electrically closer to the loads, and as a result, will be more effective at diverting surges of all origins - via the mains, the grounding system, and from surge generating loads. These protectors are known as Type 2 SPD, and may be used throughout a facility, as long as it is not used between the main breaker (or fused disconnect) and the secondary of the distribution transformer. And lastly, the terms Type 1 and Type 2 have no bearing whatsoever on the performance and capability of a given SPD, but indicate where they should be installed. A Type 2 protector may be more capable than a Type 1.

### **How close should the surge protector be mounted to the service panel?**

As close as physically possible. The surge protector should be installed immediately alongside the service panel. Any saved inches will provide a considerable improvement in the surge protector's transient suppression results. Micro-Z cable reduces cable drop to 60% of standard cable voltage drop.

### **How important is the connecting cable?**

The connecting cable is very important. Sensitive downstream equipment must not be exposed to transient voltage in excess of the CBEMA recommended levels. Micro-Z cabling has a much lower let-through voltage drop than conventional wiring. Many of MCG's surge protectors are provided with Micro-Z cabling already installed.

### **What wire size should be used for wiring up the surge protector?**

Contrary to some opinions, the wire diameter is relatively unimportant, but the shortness of the wiring connection to the service panel is very important. See *Wire Size Considerations*, page 12, for more detail.

### **What should the amperage rating of the circuit breaker be?**

For #8 AWG (8mm<sup>2</sup>) stranded wire...use a 50 Amp circuit breaker.

For #10 AWG (5mm<sup>2</sup>) stranded wire...use a 30 Amp circuit breaker.

# Wiring Diagrams - Phase Connections

**Single Phase, 2 Wire + Ground**

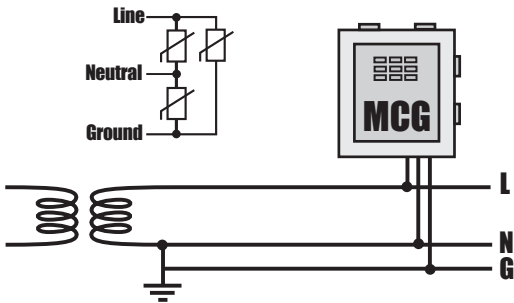

**Single Phase, 3 Wire + Ground**

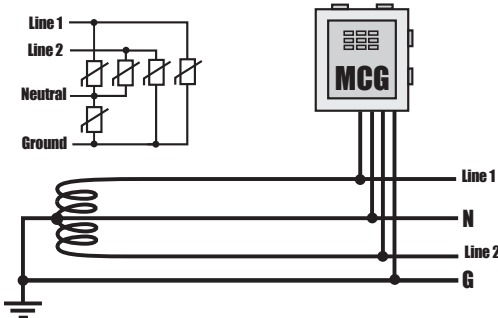

**High Leg Delta, 4 Wire + Ground**

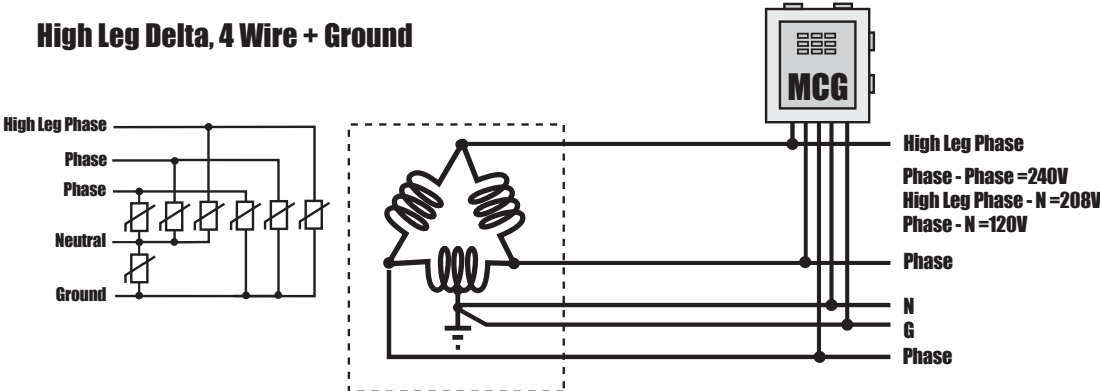

**Three Phase, Wye, 4 Wire + Ground**

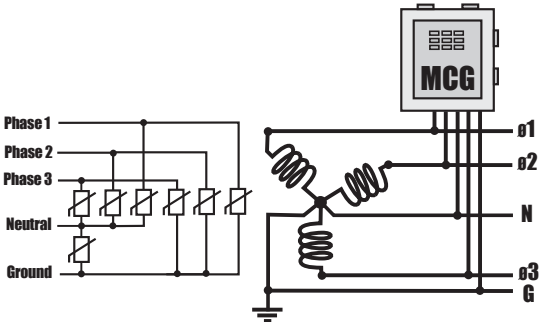

**Three Phase, Delta, 3 Wire + Ground**

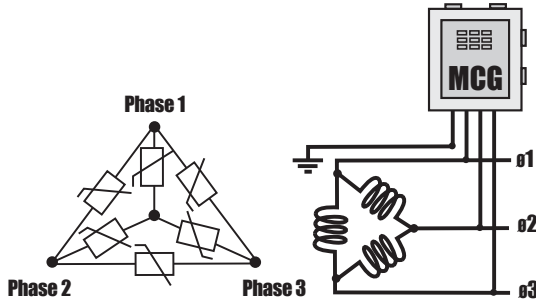

# Safety Disconnect Switch Considerations

On occasion, it may be necessary to provide maintenance or repair to a surge protector that has experienced damage in the performance of its protection function. This will require disconnecting the AC line voltages from the surge protector equipment. There are two ways to do this.

## Circuit Breaker Approach

This approach relies on the operation of a critical circuit breaker located at the service panel to remove AC line voltage from the surge protector. It has the dual advantage that no additional wire length (inductance) is added in series with the surge protector and the certainty that harmful AC line voltages are not present within the enclosure. The cost of the external circuit breaker is minimal.

## Front Panel Disconnect Switch

Manufacturers will provide, at additional cost, an internal disconnect switch, a portion of which pokes through the front panel to permit the AC line voltage to be disconnected at the surge protector's front panel. These additional switches, not originally conceived for use in surge protective devices, often require additional wiring, which is inductive. Because of the extra inductance and questionable surge current handling capacity, this type of disconnect switch should be avoided as there are better alternatives available.

Although an internal (or integral) disconnect switch is not necessary for proper surge protector function and safety, it is sometimes required by an end user or a specification. When it is required, look for one that has been carefully designed into the protector at the conceptual stage, not as an afterthought. A proper surge protector internal disconnect switch must have the following features: 1) Low impedance construction (e.g. not use wire in the surge path) so as not to add to the let-through voltage of the protection system and 2) A sufficient amount of contact area/force to handle the high peak currents associated with surges. If not, the switch will substantially increase the let-through voltage levels experienced by the equipment or the switch may be damaged from a surge event. Other than the connection cable, a surge protector should not contain any additional wiring in the surge path.

## The Bottom Line

A surge protector designed by a reputable manufacturer is the right choice, regardless of whether or not it has an internal disconnect switch. Should your application require one, it is available and is a standard feature on some protectors. If you specify surge protectors and an internal disconnect is not needed, then do not specify one.

# Ground - The Single Point Concept

There are many grounding requirements that must be addressed to ensure electrical circuits will perform as intended. In terms of protecting your equipment from transient electrical anomalies, a good ground is important. But it is *vital* that all grounds in a facility be connected together and brought to a single ground point (driven rod/cold water pipe) at the service entrance.

Separate grounds permit differences in ground potential within a facility. The result is that sensitive equipment may be exposed to differential voltages that will cause damage - even with surge protectors installed. If the grounding system of a facility is not known, protection can be assured by locating the protector at the load and grounding it to the chassis of the equipment.

# Sine Wave Tracking and EMI/RFI Filtering

*Not Always Credible*

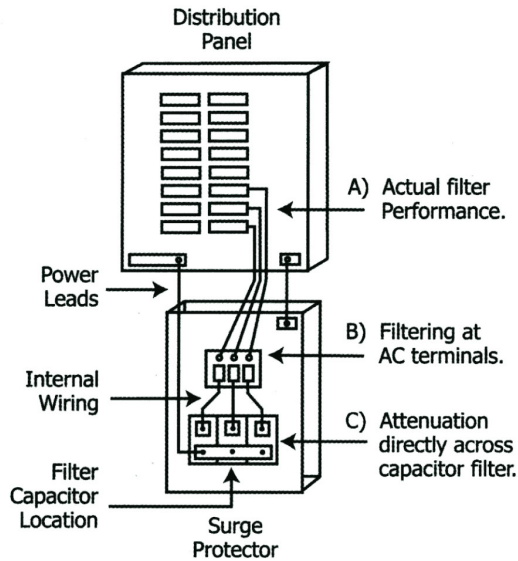

Fig. 1 Location of frequency measurements.

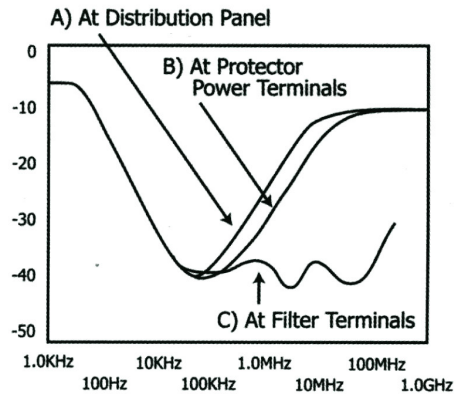

Fig. 2 Attenuation (db) vs. Frequency at different locations

## Are sine wave tracking and EMI/RFI filtering the same thing?

Yes. Sine wave tracking and/or EMI/RFI filtering is an approach that adds a high frequency filtering capability to a surge protector's normal function of limiting transient surge voltages to safe levels. This filtering is achieved by shunting the phase to neutral AC power line terminals with an inexpensive polypropylene capacitor. Filtering capability of a high quality capacitor is substantial when measured **directly** at the capacitor's terminals, but falls off sharply as the measurements are made at the AC service panel, as shown in the chart below. Most manufacturers include filtering as standard.

Location	100kHz	1MHz	10MHz	100MHz	Comments
C	40	39	37	36	Published Performance - at Filtered Module
B	40	28	11	6	Attenuation at the SPD Power Terminals
A	39	20	7	6	Service Panel - Actual Performance

## Observation

The inevitable wiring connections between the "filtering capacitors" within the surge protector and the AC power line will introduce unavoidable impedance between the power lines and the filtering elements. This wiring impedance will sharply degrade the filtering performance above 1 megahertz.

**Conclusion:** If the filtering does not show up at the service panel - it doesn't exist.



# Hybrid Protection Circuitry

Hybrid Protection Circuitry is the blending together of two (or more) technical approaches to achieve a new result that is unachievable by either technology by itself. Several hybrid approaches are promoted in the marketplace.

## Selenium Cells + MOVs Approach

In this approach, the selenium cells are designed to start conducting at some point just above the peak of the sine wave voltage. Relatively small amplitude surge currents are diverted by the selenium away from the load.

As the surge currents increase in magnitude, the turn-on threshold of the MOVs will be exceeded and almost all future increases in surge current will be diverted by the MOV protector elements. The rapidly rising selenium clamping voltage is due to its inherently small nonlinear exponent. The MOVs will now be the major detriment of the effective clamping voltage for the higher surge currents above 1000 Amps.

## Conclusion

For major transient events, 1,000 Amps and upward, the health of the protected system rests solely on the performance of the MOV devices. Selenium technology seems to be a marketing tool rather than a genuine performance improvement.

## The MOV + SAD Approach

In this approach, the Silicon Avalanche Diodes (SADs) are designed (as in the Selenium/MOV approach) to start conducting at some point just above the peak of the sine wave voltage. Relatively small amplitude transient surge currents are diverted away from the load by SADs.

Because of the SAD's very limited current handling ability, it takes many silicon avalanche diodes, in a series parallel matrix, to equal the current handling capability of one-40mm MOV on the 120VAC line. Clearly, an inefficient and very expensive proposition.

Consequently, the typical SAD module employed, per phase, contains 250 diodes in a matrix configuration having a peak current rating of 1000 Amps for a 10/1000 microsecond waveform. This low energy handling module gives the SAD/MOV approach the initial appearance of providing a low clamp voltage. **When the transient currents become large - the MOVs do all the heavy lifting.**

## Conclusion

For major transient events, 1,000 Amps and upward, the health of the protected system rests almost entirely on performance of the MOV devices. The avalanche technology has to be sheltered - it can't handle the abuse alone.

## UL Listed Versus UL Compliant: What's the Difference?

MCG Surge Protection, along with other manufacturers of SPD equipment, have long complied with UL standards in order to be able to carry the UL mark – a universally recognized symbol of safety to industry, users, specifiers, and the insurance companies that underwrite the protected equipment and facilities.

In 2006, a new standard was released titled UL Standard for Safety for Surge Protective Devices, UL1449 Third Edition, dated September 29, 2006. As a result, manufacturers were required to retest products to ensure that they comply with the new standard by 9/29/2009.

### The New Standard:

1. Consolidates TVSS and surge arrestors into one category: Surge Protective Devices (SPD).
2. Classifies transient voltage surge suppressors (TVSS) and surge arrestors into four categories - Types 1, 2, 3, 4 & 5.
3. Changes the UL rating from SVR (Suppressed Voltage Rating) to VPR (Voltage Protection Rating) which is performed at a higher surge current level of 3kA, as opposed to 500A for the SVR. As a result, VPR data are usually higher than the older SVR due to the higher amplitude surge current used to establish the VPR.
4. Adds the Nominal Discharge Current (In) test sequence which subjects the SPD to a sequence of surges at a predetermined current level.
5. Requires new markings on the protector such as SPD type (Type 1, 2, 3, 4, or 5), Nominal Discharge Current (In) rating i.e. In=5kA, Maximum Continuous Operating Voltage (MCOV), Date of Period of Manufacture, SCCR (Short Circuit Current Rating), and VPR (Voltage Protection Rating).

A new gold UL holographic label with the term “SPD” is now used to differentiate the current UL1449 3rd Ed Listed products from the previous out-of-compliance products.

**Fact:** Some companies elected to bypass UL altogether and test to the new requirements using an independent, non-UL lab. Problem – testing to the standard and being compliant to the standard does not confer a UL listing.

**Question:** If TVSS (or any other electrical equipment) is not UL-Listed, will your insurance company pay on a claim should a calamity, such as a fire or an explosion, occur?

**Conclusion:** Read the specs and visit the UL website – UL Listed means a unit may bear the UL mark. UL compliant units tested outside of UL will bear the mark of the independent testing lab, not the UL label.

MCG has invested the time and money to continue to be UL Listed. We meet the specs and can legitimately display the UL mark on our products. Please see our listing at: <http://database.ul.com/cgi-bin/XYV/template/LISEXT/1FRAME/index.htm>. Go to “Begin a Basic Search” and type: “MCG Electronics” into the company field and click on the “Search” or press “Enter” on your keyboard.

# Open Technology - Why the Secrecy?

*It is our belief that the customer needs to fully know about the product characteristics and expects clear, concise documentation on the device being considered.*

## **What is “Open Technology”?**

It is our belief that the customer needs to know fully about the product’s internal construction and to expect a clear concise description of the device’s special features.

## **Are there “trade secrets”?**

No, not really. After more than 40 years of ongoing technical investigation into the manufacture of surge suppressors, which involved the occasional dissecting of products for detailed inspection, there were seldom any surprises.

## **What about patents?**

MCG Electronics, Inc. has two United States patents that relate to surge protection.

<b>U.S. Patent No.</b>	<b>Inventor/Assigned To</b>	<b>Description</b>
5,303, 116	Glenn Grotz/MCG Electronics, Inc.	Describes internal surge protector construction to reduce inductive voltage drops by creating cancelling magnetic fields.
6,211,770B1	Michael J. Coyle/MCG Electronics, Inc.	Describes methods of combining fusing and MOV construction.

## **Why the secrecy?**

Surge protectors are constructed using available technology. An appearance of uniqueness can be created if one is careful to restrict information about its protection system. Claims of proprietary technology that is not backed by a patent, warrant skepticism.

## **The Bottom Line**

The voltage suppression technologies involved are well-known and understood. How a manufacturer addresses the fundamentals is what separates a good product from a weak or vulnerable one.

## **Advertising Terms - Exotic Uses of the English Language**

*This section shows the creative heights to which relatively uncomplicated concepts have been elevated. While attempting to shed some light, we do not claim to provide a comprehensive description of any of these concepts.*

*We leave the full explanation to the people who created them.*

### **Lattice Matrix SAD**

Silicon Avalanche Diodes connected in a series-parallel configuration.

### **EMI/RFI Filter System**

In hard-wired surge protectors, the simplest kinds of high frequency filters typically employing a few capacitor(s) to shunt the AC power line, are used. The use of capacitors and long wiring in these applications greatly limits their ability to effectively bypass high frequency signals. If filtering is important in your application, keep the protector leads as short as possible (less than 2 feet is preferred.)

### **Sine Tracking**

A variety of terms that use various combinations of the words *sine*, *wave* and *tracking*. Actually, Sine Wave Tracking is simply one or more capacitors shunting the AC power line to attenuate high frequencies that appear on the power lines. See sections on *EMI/RFI Filtering* and *Sine Wave Tracking*.

### **“Unique” Chemical Compound**

An epoxy compound used to encapsulate modules. Frequently, units are encapsulated to prevent customers from knowing what is inside. Claims are made that MOV heating is absorbed by the epoxy, thus allowing the MOV to operate at a reduced temperature. In reality, the epoxy encapsulated MOVs will absorb the transient-generated heat long before any heat transfer can occur through the epoxy.

### **99% Silver Links**

A fuse by any other name is still a fuse.

### **Hybrid Protection**

Combining two or more surge protection technologies to provide “enhanced” performance. See *Hybrid Protection Approaches*, page 25, for more details.

### **Silicon Arrestor**

A conventional spark gap buried in sand (silicon).

# Standards - Industry and Safety

## **ANSI C62.41-2002 - IEEE Recommended Practice on characterization of surges in low-voltage (1000V and less) AC power circuits.**

Describes the AC power line environment in a simplified form and establishes a set of representative surge waveforms. It tends to simulate the dynamics of the AC power line environment.

## **ANSI-C62.45-2002 - IEEE Guide to Surge Testing for Equipment Connected to AC Power Circuits**

Provides technical guidance for use of surge testing equipment in the evaluation of a surge protector. The document calls attention to the important safety aspects of surge testing. This standard does not confer qualification, it merely tests the protector.

## **NEMA LS-1 - 1992 Low Voltage Surge Protection Devices**

Establishes a guide for manufacturers of TVSS equipment to encourage uniformity of specifications. NEMA LS-1 testing by a third party insures that a manufacturer's product meets its published peak current specifications.

## **UL 1283, 5th Edition - Electromagnetic Interference Filters**

This standard reviews the construction and suitability of the EMI filter for safe use on 1000VAC (or less) power lines.

It does not test the EMI filter's noise attenuation vs. frequency data. Some manufacturers are positioning their reputed filter attenuation figures to be adjacent to the UL 1283 discussions and thus infer a UL 1283 endorsement. See section on EMI/RFI Filtering.

## **UL 1283 is only a safety specification, not a performance standard.**

## **UL 1414, 6th Ed. - Across the Line...Capacitors**

This standard evaluates across-the-line capacitors for safety only when used in L-N and L-G models on surge protectors. This specification does not evaluate any filtering characteristics that may occur as a result of their use.

## **UL 1414 is only a safety standard.**

## **UL 1449, 2nd Ed. - UL Standard for Transient Voltage Surge Suppressors**

This standard evaluates the safety aspects of a surge protector connected across the AC power line and measures the Suppressed Voltage Rating. (SVR). The SVR rating is printed on the product label. A surge protector might have 450 Volts clamping level but will receive a UL (SVR) rating of 500 Volts. The SVR rating is a group category rating - not necessarily the actual clamp voltage rating.

## **UL1449, 2nd Ed. including the requirements of Feb. 9th, 2007.**









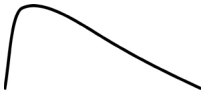

As of February 9th, 2007, a surge protector which is UL1449 2nd Edition Listed must be compliant with the new requirements. Products were tested to the new safety requirements during recent UL1449 file review. **Only products meeting these new requirements and are tested using UL labs, are able to carry the UL mark.**

## **UL1449, 3rd Ed. Sept. 29th, 2006 - UL standard for safety for surge protective devices.**

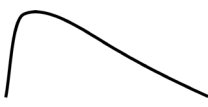
This is the latest revision of UL1449. It became effective in 2009.

# ANSI C62.41-2002 Standard

## Protection Categories

Service Entrance	Cat. C	Cat. B	Cat. A
Category	1.2/50 $\mu$ s	8/20 $\mu$ s	
C1	6kV	3kA	
C2	10kV	5kA	
C3	20kV	10kA	
			
	Impulse	Impulse	
<b>Mid-Building</b>			
Category	1.2/50 $\mu$ s	8/20 $\mu$ s	0.5 $\mu$ s 100kHz
B1	2kV	1kA	170A 2kV
B2	4kV	2kA	330A 4kV
B3	6kV	3kA	500A 6kV
			
		Impulse	Impulse
			
			Ringwave
<b>Local Panel</b>			
Category			0.5 $\mu$ s 100kHz
A1			2kA 70kV
A2			4kA 130kV
A3			6kA 200kV
			
			Ringwave

# Glossary of Technical Terms

## Clamp Voltage

The clamp voltage is the measured maximum voltage appearing across a surge protector when a standard waveform (simulating a lightning transient) is applied to the surge protector.

Some manufacturers, to gain a slightly lower clamp voltage, will narrow the headroom spread by using lower voltage MOVs - this greatly increases the likelihood of protector failure in the field. **All in all, a big risk for a very small, if any, performance improvement.**

## Headroom

Headroom is the difference in voltage between the peak of the sine wave and a higher threshold voltage level where the MOV starts to turn on. If the headroom spread is too small, the MOVs may conduct more frequently resulting in a shorter MOV life. Headroom margins of 15% and greater address this issue with virtually no effect on suppressor performance. In some areas, power line fluctuations can exceed 15%. Prudent design requires higher clamp voltage MOVs in these situations. For example, certain utilities (or countries) often have voltage swells exceeding 115% on a regular basis. These swells are harmless to equipment but can cause premature failure of a surge protector with inadequate headroom. If the AC regulation is poor, be sure to use a protector with sufficient headroom.

## Let Through Voltage

Sensitive equipment located downstream on the AC power lines will be exposed to the clamp voltage of the surge protector while it is diverting the transient to ground. It is always desirable to minimize let-through voltage.

## MCOV

MCOV is the Maximum Continuous Operating Voltage that can be applied to the surge protector without damaging it. Utilities generally maintain the line voltages to tight tolerances. If the line voltage rises above the specified MCOV for a sustained period of time, the surge protector's MOVs will begin to conduct and protector failure will eventually occur unless certain measures are taken.

## Rated Voltage

The rated protector voltage corresponds to the nominal line voltage supplied by the utility. The protector type must conform to the utility's service configuration, i.e., single or three phase, delta or wye, etc.

## Threshold Voltage

Threshold Voltage is the turn-on point at which a surge protector starts to conduct 1mA of current. By itself, this is an incomplete indicator of performance.

# Warranty

Read (and understand) the fine print. Some warranties, at first glance, promise many great things, but in reality are meticulously crafted so that it is legally impossible to collect. This is usually the result of disclaimers which protect the manufacturer. When considering a surge protector manufacturer, **avoid** ones with the following types of warranties:

**1. Connected Equipment Warranties** - These types of warranties, on the surface, claim to replace not only the protector, but the protected equipment as well if the equipment is damaged. But if you read the fine print you will often see a disclaimer which states that the warranty is void if equipment is damaged by an act of God (i.e. lightning.)

**2. Warranties that require a lawyer to interpret** - If a warranty is full of legalese that is too difficult to understand, odds are it is designed to protect the manufacturer and not the consumer. A warranty should be clear and easy to understand.

**3. Warranties that do not have "free lifetime replacement of modules and fuses"** - The protection modules and fuses are the heart of a surge protector. If a manufacturer does not stand behind their products and offer a free lifetime replacement warranty on the modules and fuses, one should question this. It means that the components probably will not last long and as a result, you will have to eventually purchase new ones.

## What MCG Offers

**MCG supplies a 20-year "No-Nonsense" Warranty** - Should the basic surge protector assembly suffer damage while in service, MCG will replace the unit immediately, without charge. (See MCG warranty for full details at [www.mcgsurge.com](http://www.mcgsurge.com)).

**MCG provides free replacement modules and fuses for life** - Should any module or fuse need to be replaced in a surge protector, MCG will replace them without charge, beyond the twenty-year warranty.

**Quality - ISO 9001:2008 Certified** - MCG will engineer, manufacture, and deliver surge protection equipment that will meet customers expectations at a fair and reasonable price, and back it up with our "No-Nonsense" Warranty.

At MCG, we are committed to our customers, employees and suppliers. Our course of action is directed by utilizing the principles of "Continuous Quality Improvement". Our commitment to "Continuous Quality Improvement" drives us to excel in our industry through the establishment of objectives that are reviewed and upgraded on a scheduled basis.

# Index

## Page

Advertising Terms	28
Component Life - MOV	19
Construction, Micro-Z Cabling vs. Conventional	14
Current, 1mA Threshold	4
Distribution Transformer	21
Economic Justification for Surge Protection	6
EMI/RFI Filtering	24
Enclosures, NEMA 4, 4X, 12	20
Environment - Altitude, Moisture, Temperature	20
Fuse - MOV Coordination, KAIC Rating	16
Ground - The Single Point Concept	23
Headroom	31
Hybrid Protection Approaches - MOV/SAD, MOV-Selenium	25
I Peak	9, 16
I/O Port Failures - Data Line Protection	3
Impedance, Internal/External Wiring	11
Inductance	11
Installation Notes	21
Joule Rating	20
KAIC Rating	16
Let Through Voltage	12
Lifetime Rating	20
Lightning - Multiple Strikes, Utility Lines, Etc..	5
Micro-Z Concept	13
Modular Construction	18
Monitoring - LEDs, Beepers, Etc..	19
MOV Life	19
Multiple Pathways - Fuse/MOV Combinations	17
NEMA LS-1	9
Open Technology - Patents, Trade Secrets	27
Product Comparison Sheet	8
Protection Categories - ANSI, UL	29
Protector - Requirements for Proper Coordination	16
Redundancy, False Redundancy	17
Response Time - Transients	4
Service Panels - Main/Distribution. Branch, Local	7
Sine Wave Tracking	24
Standards - ANSI, IEC, NEMA, UL	29
Standards - CBEMA	10
Surge Protection Device (SPD) - Types of	25
UL Listed Versus UL Compliant	26
Voltage - Let Through	12
Voltage - Rated, MCOV, Threshold, Clamp, Let-Through	31
Warranty	31
Waveforms	30
Wire Size Considerations	12
	9